

REVISION RECORD

REV	DESCRIPTION	DFTM	DCR
1	Update to NP1105 & 100.06. Added Notes.	KP	1650
2	Change Served Shield Lay, Braid Gears, See Attached	SB	2041

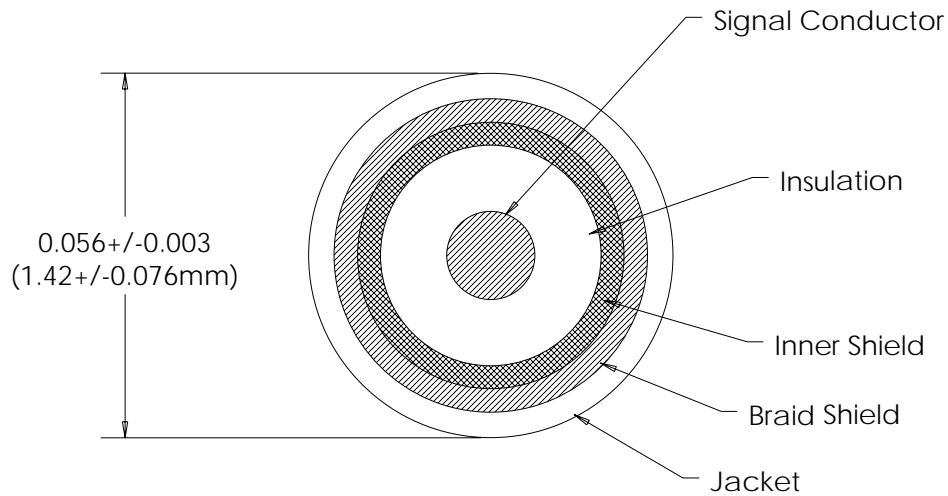

CONSTRUCTION

Signal Conductor: 0.0113" +/- 0.0001" (0.29 +/- 0.0025mm), Silver Plated Copper per ASTM B-298
 Insulation: FEP per applicable paragraph MIL-DTL-17, 0.0368" +/- 0.001" (0.935 +/- 0.025mm) OD
 Inner Shield: Helically Overlapped Flat Silver Plated Copper per ASTM B-298
 Braid Shield: Flat Silver Plated Copper per ASTM B-298, >90% Coverage
 Overall Shield Diameter: 0.046" +/- 0.002 (1.12 +/- 0.05mm)
 Jacket: FEP in accordance with MIL-DTL-17, Type IX
 Wall Thickness: 0.005" (0.127mm)
 Color: Blue

Freq (GHz)	Attenuation (dB/100 ft)	Avg Power (W)
0.5	25	61
1	35	43
2	52	30
4	80	20
8	120	13
12	140	10
18	180	8

ELECTRICAL

Impedance: 50 +/- 1 ohms
 Velocity Of Propagation: 70%
 Capacitance: 29 pF/ft (95 pF/m)

GENERAL

Temperature Rating: -65C to 165C
 Static Bend Radius: 0.2" (5.0mm)
 Dynamic Bend Radius: 0.4" (10.0mm)
 Weight: 3.5 lbs/1000ft
 Patent Pending



TEMP-FLEX CABLE, INC.

26 Milford Road South Grafton, MA 01560 Phone: 508-839-5987 Fax: 508-839-4128

CAGE CODE: 0CGL7

This document is the property of TEMP-FLEX. It may not be disclosed, reproduced, or otherwise used without permission.

DFTM: SB DATE: 11/20/09

TITLE:
Low Loss Microwave Coax,
29 AWG

PART No:

047SC-2901

APPD: RP DATE: 11/20/09

SHEET 1 OF 1

REV: 2