

REVISION RECORD

REV	DESCRIPTION	DFTM	DCR
6	Braid and Flat Shield Raw Material Part # Change. See Attached.	RL	2436
7	Flat Served Shield Lay Length Change. Add Braid Shield Supplier.	RL	2832

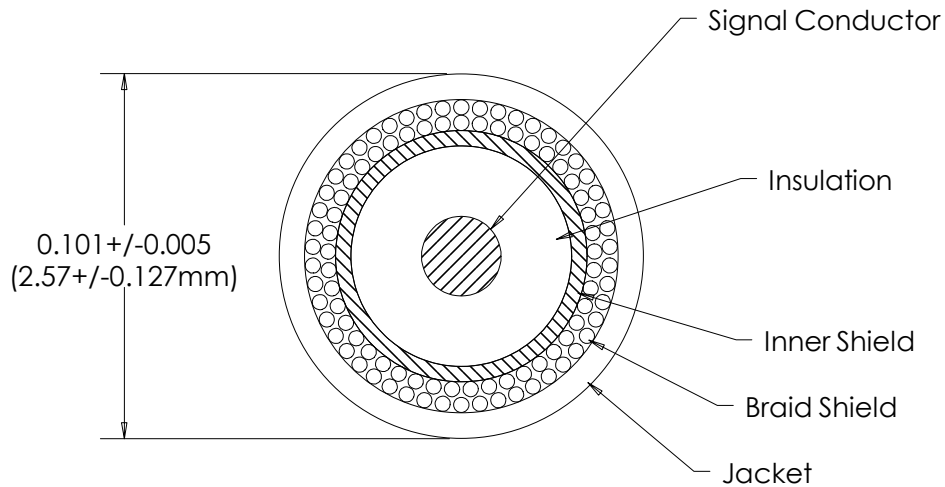

CONSTRUCTION

Signal Conductor: 0.0201" +/- 0.0002" (0.51 +/- 0.0051mm), Silver Plated Copper per ASTM B-298
 Insulation: FEP per applicable paragraph MIL-DTL-17, 0.065" +/- 0.001" (1.65 +/- 0.0256mm) OD
 Inner Shield: Helically Overlapped Flat Silver Plated Copper per ASTM B-298
 Braid Shield: 40 AWG Silver Plated Copper per ASTM B-298, >90% Coverage
 Overall Shield Diameter: 0.085" +/- 0.002 (2.18 +/- 0.05mm)
 Jacket: FEP in accordance with MIL-DTL-17, Type IX
 Wall Thickness: 0.008" (0.19mm)
 Color: Blue

ELECTRICAL

Impedance: 50 +/- 1 ohms
 Velocity Of Propagation: 70%
 Capacitance: 29 pF/ft (95 pF/m)

GENERAL

Temperature Rating: -65C to 165C
 Static Bend Radius: 0.3" (7.6mm)
 Dynamic Bend Radius: 0.6" (15mm)
 Weight: 13 lbs/1000ft
 Patent Pending

Freq (GHz)	Attenuation (dB/100 ft)	Avg Power (W)
0.5	16	168
1	24	117
2	34	80
4	48	55
8	70	37
12	88	32
18	111	23



TEMP-FLEX CABLE, INC.

26 Milford Road South Grafton, MA 01560 Phone: 508-839-5987 Fax: 508-839-4128

CAGE CODE: 0CGL7

This document is the property of TEMP-FLEX. It may not be disclosed, reproduced, or otherwise used without permission.

DFTM: RL DATE: 12/21/11

TITLE:
Low Loss Microwave Coax,
24 AWG

PART No:

086SC-2401

APPD: KP DATE: 12/21/11

SHEET 1 OF 1

REV: 7